

series
892E3
2-Stage Servovalve
Rated flows up to 230 l/m

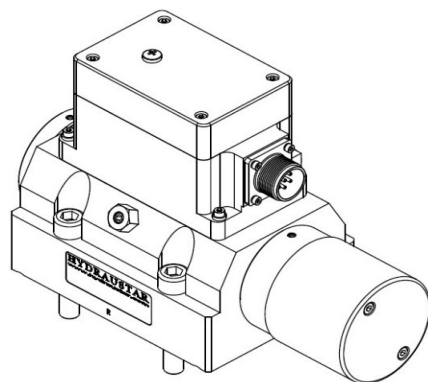

Features

- Maximum operating pressure 315 bar
- Electric feedback at main stage spool
- ISO 10372-04-04-0-92 mounting pattern
- External pilot supply (5 port)
- Suitable for 3-way or 4-way applications
- Low hysteresis & zero point drift
- High spool drive forces
- Spool in bushing design
- Long life Sapphire Technology



HYDRAUSTAR
ZA des Garennes
F41100 St FIRMIN des PRES

www.hydraustar.com

ST-892E3-2021.1-Fr

Benefits and Features

Sapphire ball in slot design

- Incorporated into Star designs since 1988
- Many billions of cycles per service life
- Increased spool life due to spool rotation
- Ultra low coefficient of friction sapphire to steel
- Feedback mechanism unhindered by spool rotation
- Extended warranties available



Safety

- Flame proof
- Intrinsic safety
- Class, Div & Zone coverage
- Mechanical failsafe
- Double & triple coil redundancy



Quality



- Independent audit process is our commitment on quality
- Focus on customer needs and expectations
- Delivery schedules on time
- Continual improvements on products and services
- Maintaining design and manufacturing integrity

Custom spool lap & bushing port geometries

- Zero overlap
- Overlap (closed center)
- underlap (open center)
- Dual gain
- Asymmetric gain

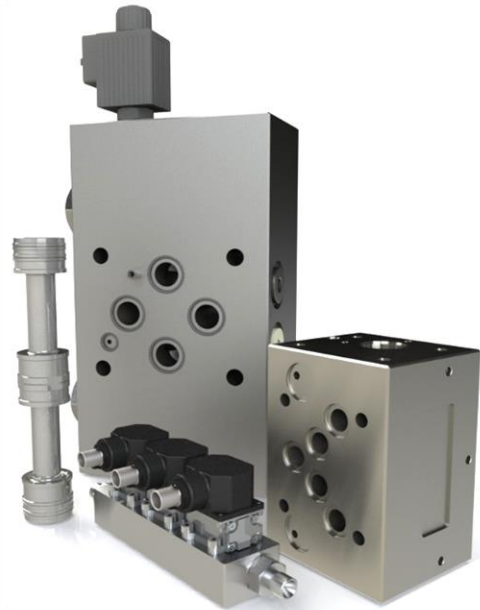
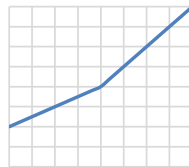
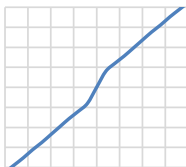
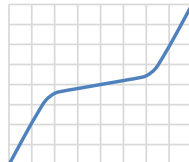
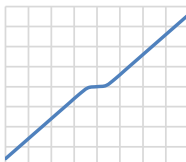
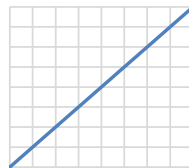

Special projects

- Compact servo designs
- Special interfaces
- Modular components



Sapphire flow

- Ensuring first stage stability
- Precisely matched flow properties
- Long life in extreme environments



Sealing materials

- Nitrile
- Fluorocarbon (Viton)
- Ethylene-Propylene
- Fluorosilicone



Special connectors

- MIL-C-5015
- MIL-DTL-38999
- Conduit style male/female
- Hermetic

Technical data

Hydraulic

Nominal flow ratings [$\pm 10\%$]	at 70 bar Δp	95, 150, 230 l/m
Operating pressure (max)	Ports	P, C1, C2, R, Px
Seal material	NBR, FPM	315 bar
Fluid viscosity range (recommended)		10 to 100 mm ² /s (cSt)
Fluid type		Mineral oil to ISO 11158, DIN 51524 or equivalent MIL-H-5606 Kerosene Water glycols others on request
Filter rating (recommended)	Pressure line Off-line	Beta 10 = 200 (10 μ m abs), non by-pass & indicator Beta 2 = 1000 (2 μ m abs)
Fluid cleanliness	ISO 4406: 1999 minimum recommended	16/ 14/ 11 15/ 13/ 10

Operational parameters

Hysteresis		$\leq 0.5\%$ without dither
Threshold		$\leq 0.1\%$ without dither
Null shift	ΔT 40°C	$\leq 2.0\%$
Internal leakage	140 bar supply (1% overlap) 95 l/m 150, 230 l/m	≤ 2.0 l/m ≤ 4.0 l/m
Load pressure difference	1% input	$\geq 30\%$ of supply pressure can be as high as 100%
Response time	0-100% rated spool stroke 95, 150 l/m 230 l/m	9 ms 17 ms
Mounting pattern		ISO 10372-06-05-0-92 with X port
Mounting position		Any, fixed or movable (1)
Weight	std unit additional filter housing	3.7 kg 5.0 kg
Design protection	EN 60529	IP 65
Shipping protection		Sealed base plate
Vibration		30 g all axis, 5 Hz to 2,000 Hz
Shock		30 g all axis
Seal material options		NBR, FPM
Temperature range		-20 to 80 °C

(1) Depending on valve orientation the main stage spool may drop when supply pressure is switched off leading to unwatered startup bump. If so then an external pilot supply model (892) is suggested, this allows startup of the first stage via the X port prior to applying pressure at the main stage.

Technical data - Electrical details

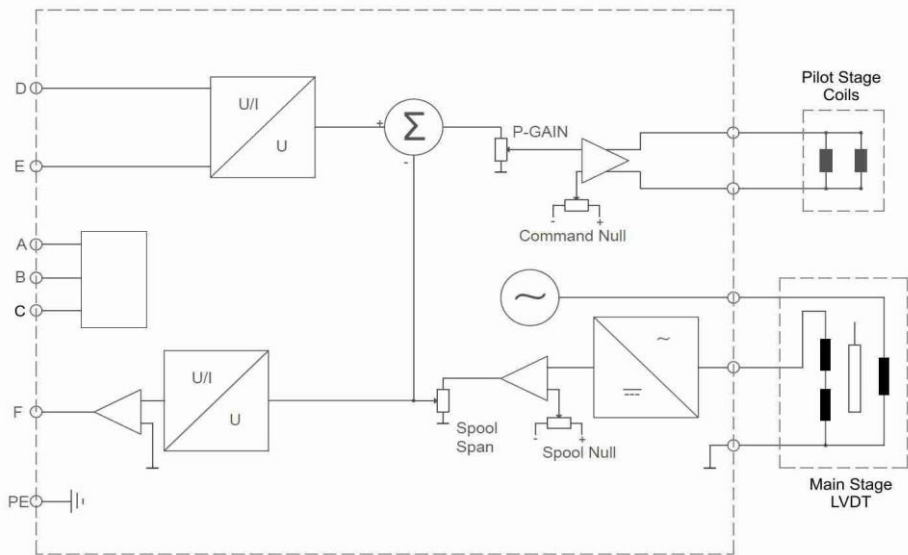

Factory set options are as follows

Pin	Function	Dual rail power supply (code 'D')
A	Supply	+15 Vdc (+14.5...+18 Vdc)
B	Supply	-15 Vdc (-14.5...-18 Vdc)
C	Supply / signal ground	0 V
D	Input rated command (differential)	±10 V or ±10 mA
E	Inverse	
F	Main stage spool position O/P	±10 V or ±10 mA or +4...+20 mA
PE	Protective earth	

Pin	Function	Single rail power supply (code 'S')
A	Supply	+24 V (+20...+28 Vdc)
B	Supply / signal ground	0 V
C	n.c	
D	Input rated command (differential)	±10 V or ±10 mA
E	Inverse	
F	Main stage spool position O/P	±10 V or ±10 mA or +4...+20 mA
PE	Protective earth	

Power supply

Current (mA): < 100 each rail (typically 50)
Ripple (mV p-p): < 100

Command signal

Phasing: when input at pin D = +ve with respect to pin E causes flow from P»C2, C1»R
Voltage input: impedance 1 Mohm
Current input: impedance 200 ohm

Actual spool position output

Voltage output: Output impedance <10 ohm, minimum receiver impedance 1 kohm
Current output: Output impedance > 100k ohm, minimum receiver impedance 30 ohm, maximum receiver impedance 400 ohm
+4...+20 mA: at +12 mA spool is in centred position

Protection

Reverse Polarity: Indefinite
Over-voltage: Absolute max +/- 20 V DC

Technical data

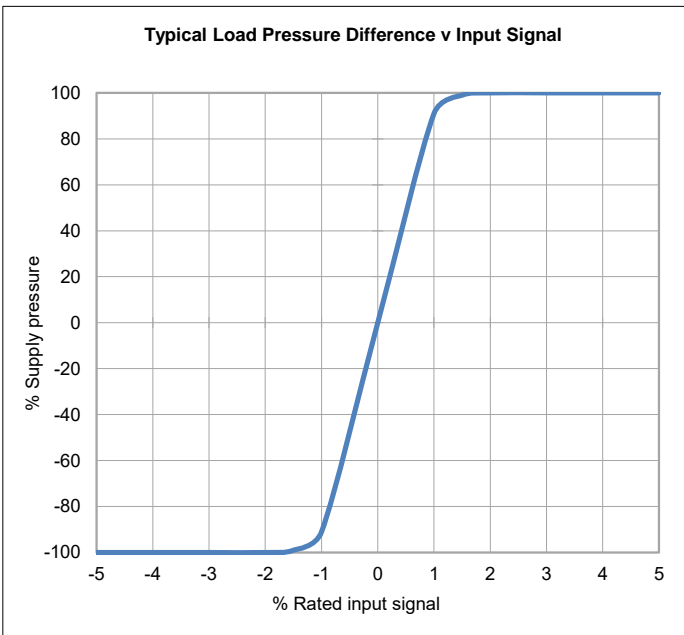
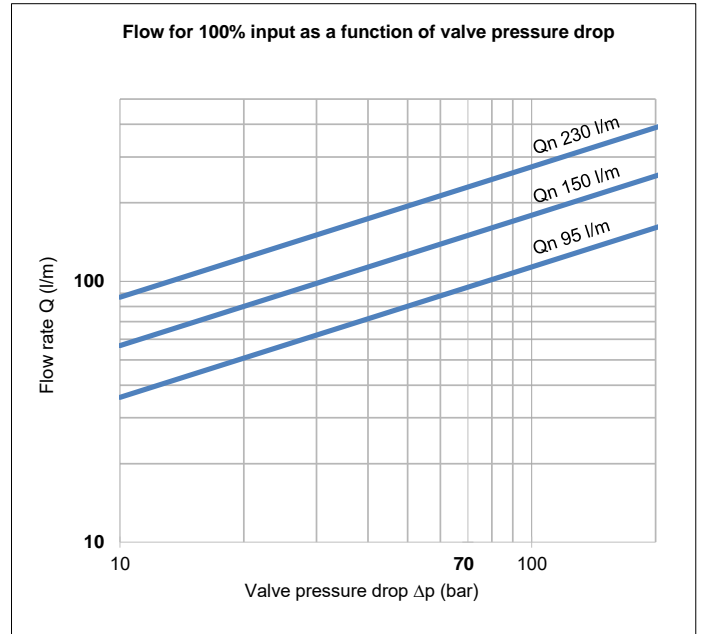
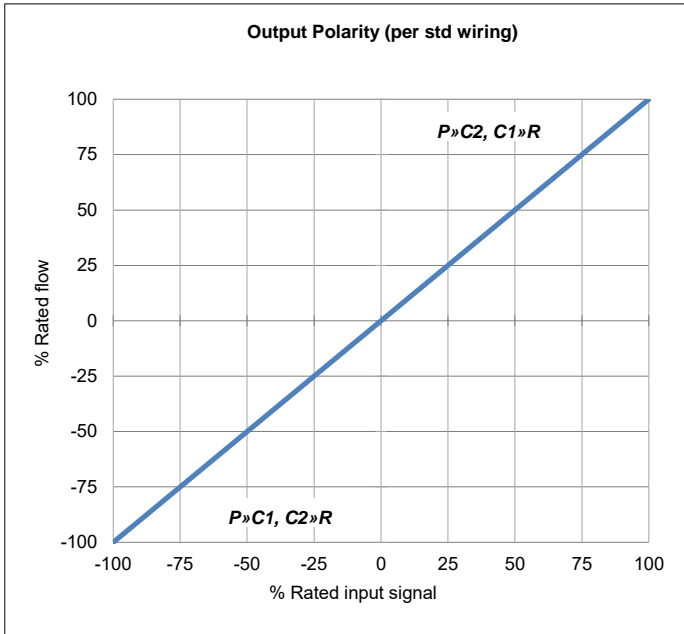

The flow tolerance for standard servovalves is $\pm 10\%$ of the rated flow at 100% rated input signal.

Rated Signal [In] is the specified input voltage or current of either polarity to produce rated flow. Rated input does not include null bias values.

Rated flow corresponds to the flow at rated input at 10 bar or 70 bar, with no load, therefore in 4-way valves there will be a pressure drop of 5 bar or 35 bar respectively across each land.

Load pressure difference versus input signal indicates typical differential pressure gain between ports C1 (A) and C2 (B) for standard lap spools. Negative and positive overlap change this characteristic significantly.

Internal leakage comprises of tare first stage and laminar leakage between spool and sleeve. With critical lap conditions in 4-way designs the leakage peaks through the null region.

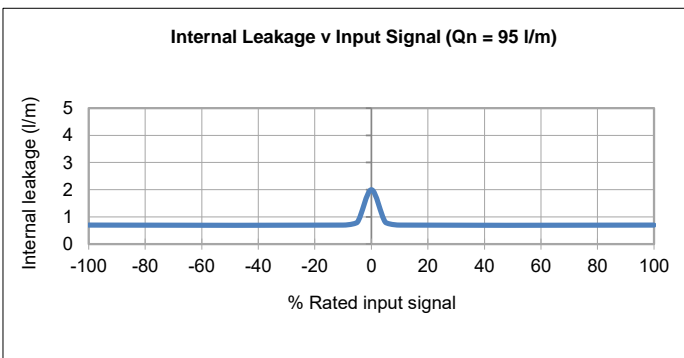

Technical data

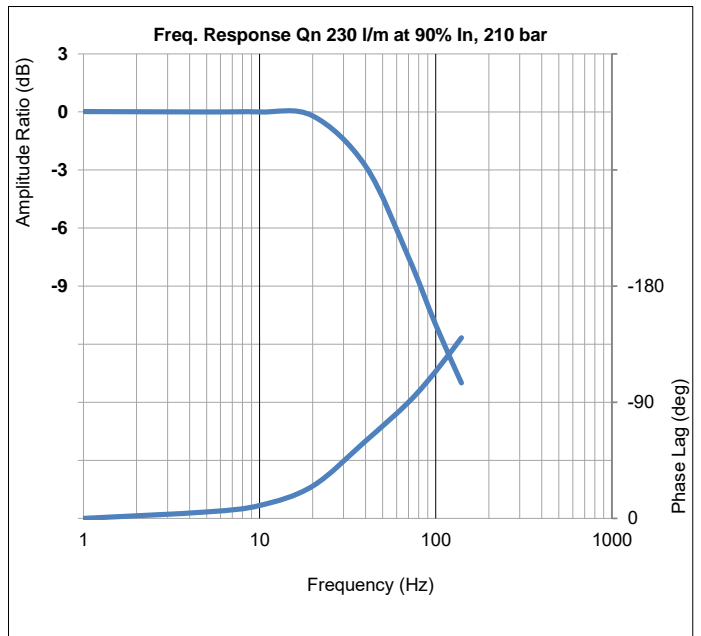
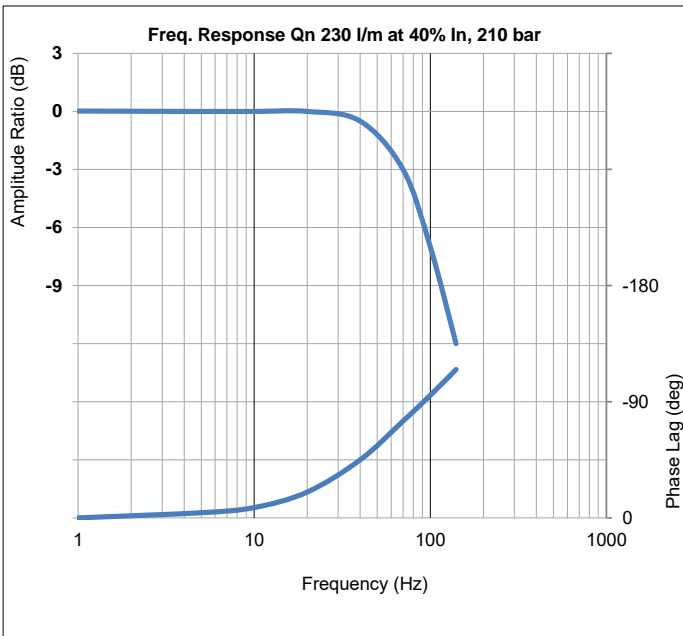
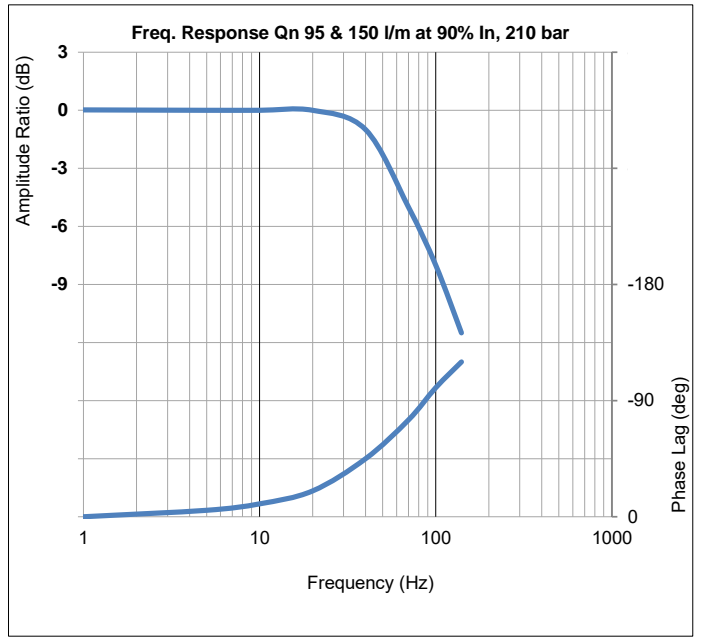
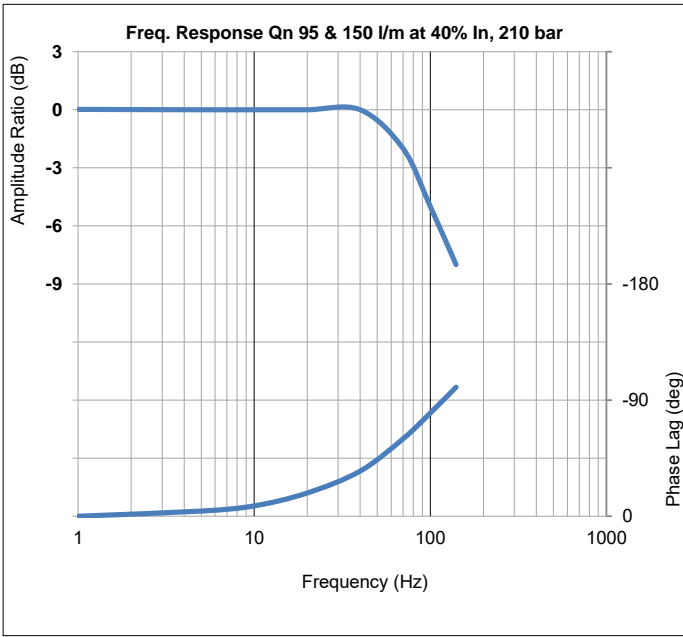

892E3 series INSTALLATION DETAILS

Mounting screws	Skt head cap screws M10 x 55 10.9 ISO 4762
Porting details	P, C1, C2, R ports $\varnothing 15.8$, $\square \varnothing 23.8 \nabla 1.40$ on 50.8 P.C.D. X port $\varnothing 3$, $\square \varnothing 12.7 \nabla 1.40$
Interface seals	Ports P, C1, C2, R - ID 20.35 x $\varnothing 1.78$ O-Ring Ports X - ID 9.25 x $\varnothing 1.78$ O-Ring
(1) Optional filter housing	Additional pilot stage filter stage, replacement filter element P/N: SRS1479
(2) Null adjust (electrical)	Remove screw plug, insert appropriate potentiometer driver to attain desired null / offset condition

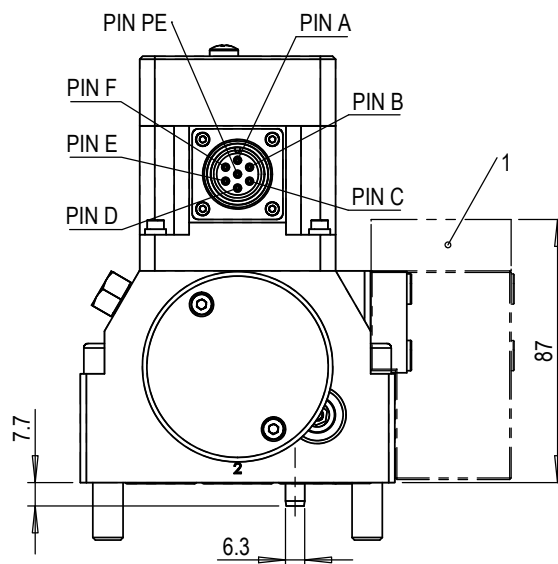
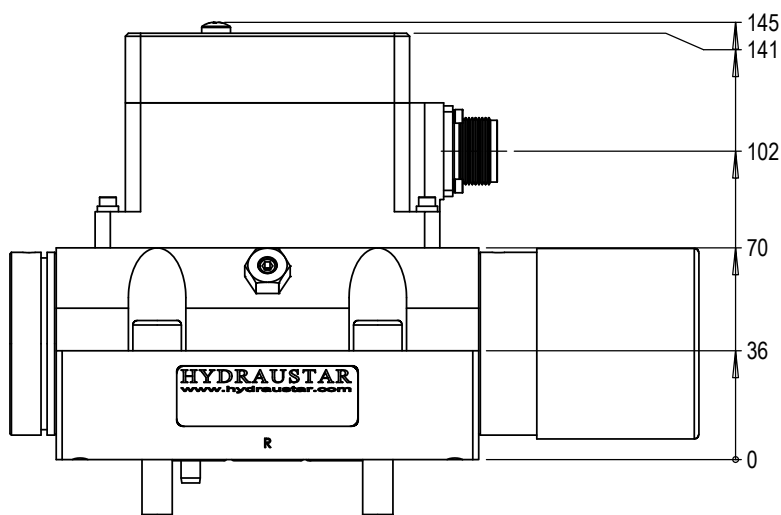
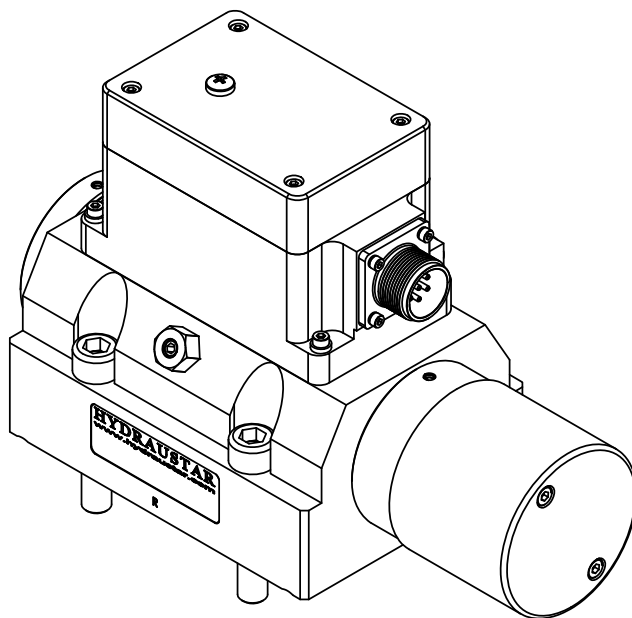
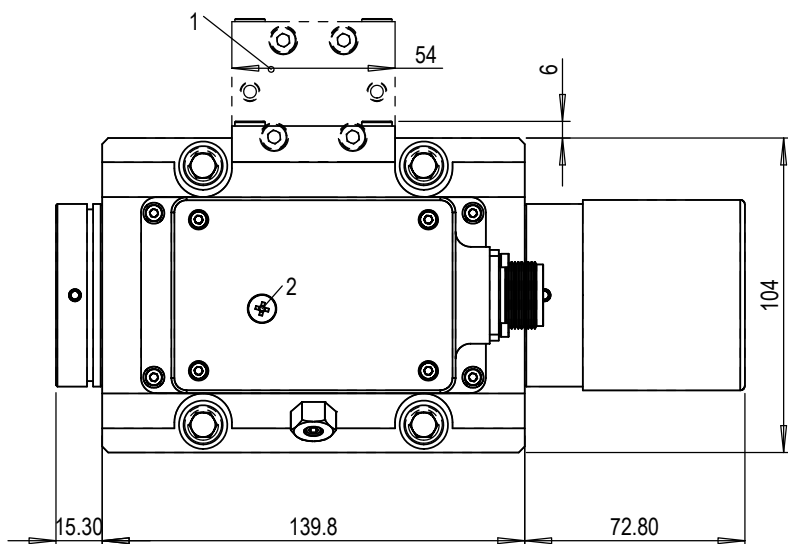

Mounting interface conforms to ISO 10372-06-05-0-92										
	P	C1	C2	R	X	F1	F2	F3	F4	G
size	$\varnothing 15$	$\varnothing 15$	$\varnothing 15$	$\varnothing 15$	$\varnothing 3$	M10	M10	M10	M10	$\varnothing 8 \nabla 9$
x	36.50	11.10	61.93	36.50	55.60	0	73	73	0	11.10
y	17.38	42.80	42.80	68.23	4.60	0	0	85.60	85.60	23.70
Surface flat within 0.01 / 100 : finish better than 0.8 μm										

